

Manual Instruction

A730-2 12V

(2020006)

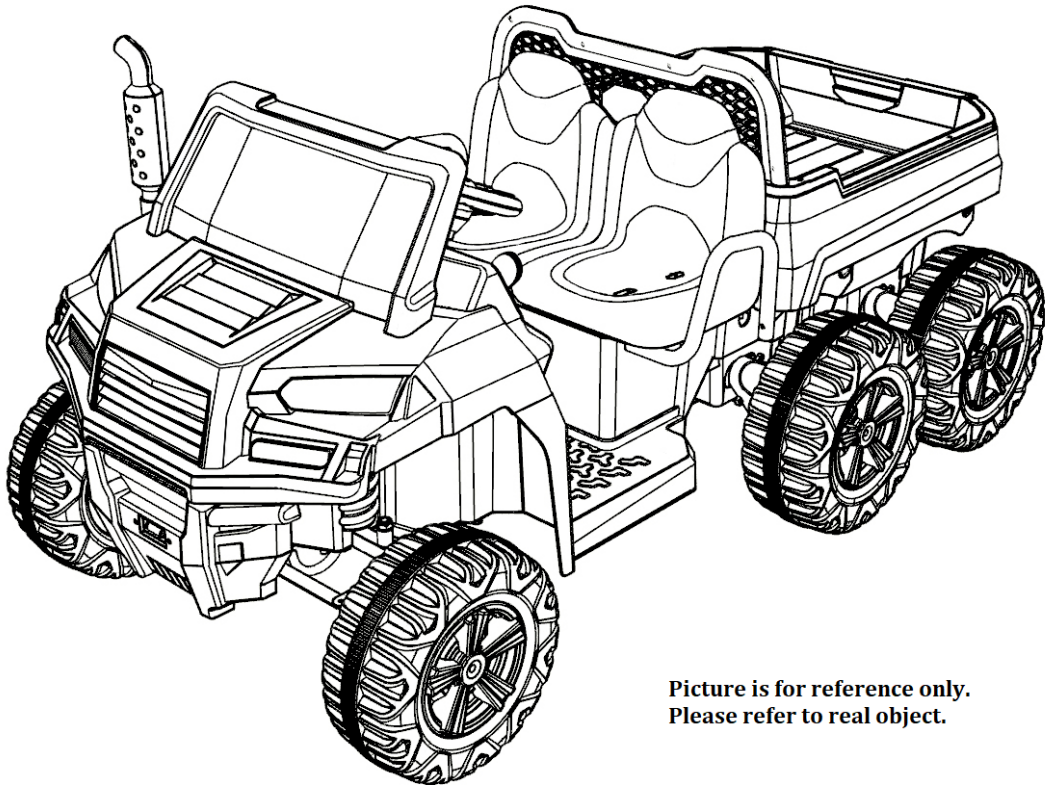

Picture is for reference only.
Please refer to real object.

Special Note:

The car hopper is a trim only. No loading people or goods.



- ◆ Please read the manual carefully before assembling;
- ◆ Preserve the manual properly for future reference;
- ◆ The manual is for assembling and using reference only. Details will be possibly improved and updated, including structure, appearance, packing, functions, and etc. Please refer to the real object as standard if there is something different from the manual.

1. Before Assembling

Warning!

Choking Hazard: Small parts, Not for kids under 3 years. Dispose plastic bags carefully.

It's dangerous to kids. Adult assembly required. Use care when unpacking as components to be assembled may pose small parts/sharp edge hazard.

Check if the charger is in good state, including the wire, socket, and all details. Stop use it if it looks broken in some way, till it's fixed.

Tools required(self-provided):



Phillips screwdriver



socket wrench

2. Specifications:

Motor: 12V540(10000rpm) * 4

Battery: 12V10ah*1/12V7ah*2/12V10ah*2

Charger: 12V1000mA/12V1500mA/12V2000mA

Fuse: 15A

Max Speed: 5-7 km/h

Suitable Age: 3 years+

Maximum Loading Capacity: 60 kg

Item size: 1500×790×720 MM

Charging time: 8-12 hours

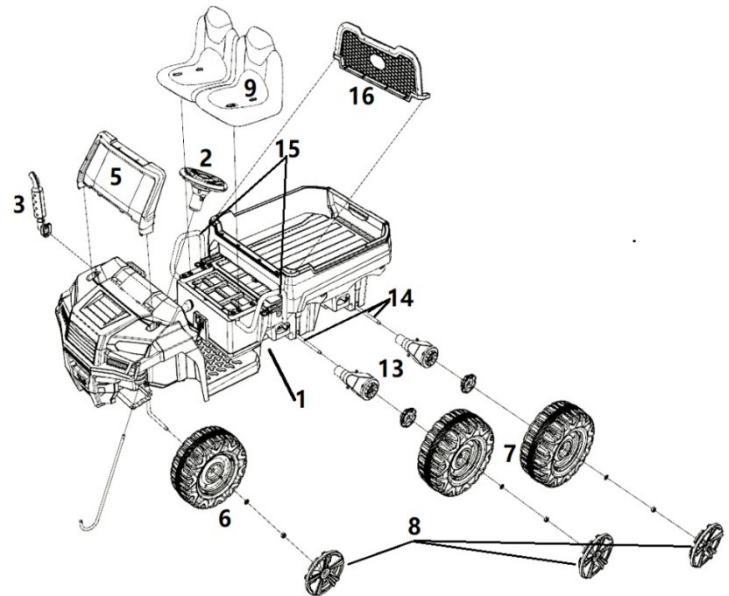

3. Exploded View and Parts List

| No. | Parts Name | Qty | No. | Part Name | Qty |
|-----|-------------------------|-----|-----|--------------------|-----|
| 1 | Body | 1 | 9 | seat | 1 |
| 2 | Steer Wheel | 1 | 10 | charger | 1 |
| 3 | chimney | 1 | 11 | Screw kit | 1 |
| 4 | Remote control | 1 | 12 | manual | 1 |
| 5 | windshield | 1 | 13 | Motor (Left&right) | 4 |
| 6 | Front wheel | 2 | 14 | Rear axle | 1 |
| 7 | Rear wheel (driving) | 4 | 15 | Metal rail | 1 |
| 8 | Wheel cover | 4 | 16 | Hopper baffle | 1 |

Note: some parts need to be fixed from 2 sides.

| Screw Kit | | | |
|-----------|--------------------|-----|-------------------------|
| | parts | qty | Where to use |
| A | tapping screw 4x12 | 8 | Front turning structure |
| B | tapping screw 4x12 | 1 | chimney |
| C | tapping screw 4x12 | 6 | Hopper baffle |
| D | tapping screw 4x12 | 4 | seat |
| E | tapping screw 4x12 | 2 | windshield |
| F | Shim M10 | 1 | Steer rod hook |
| G | split pin | 1 | Steer rod hook |

4. Turning structure and rod assembling

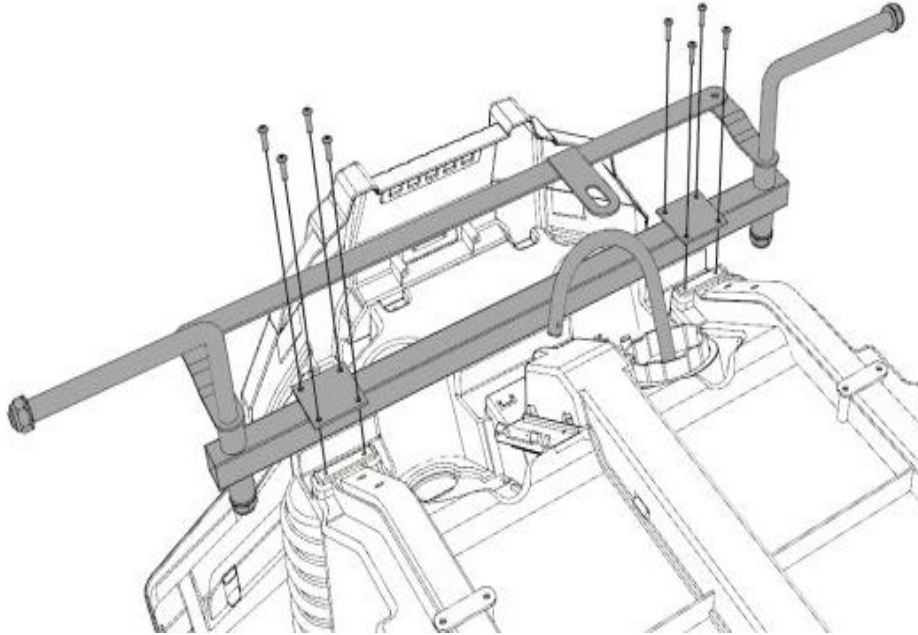

A. Turn the turning rod hook, and put the turning structure onto the plastic body, make sure the screw holes on right position, then fix it by 8 pcs tapping screws.

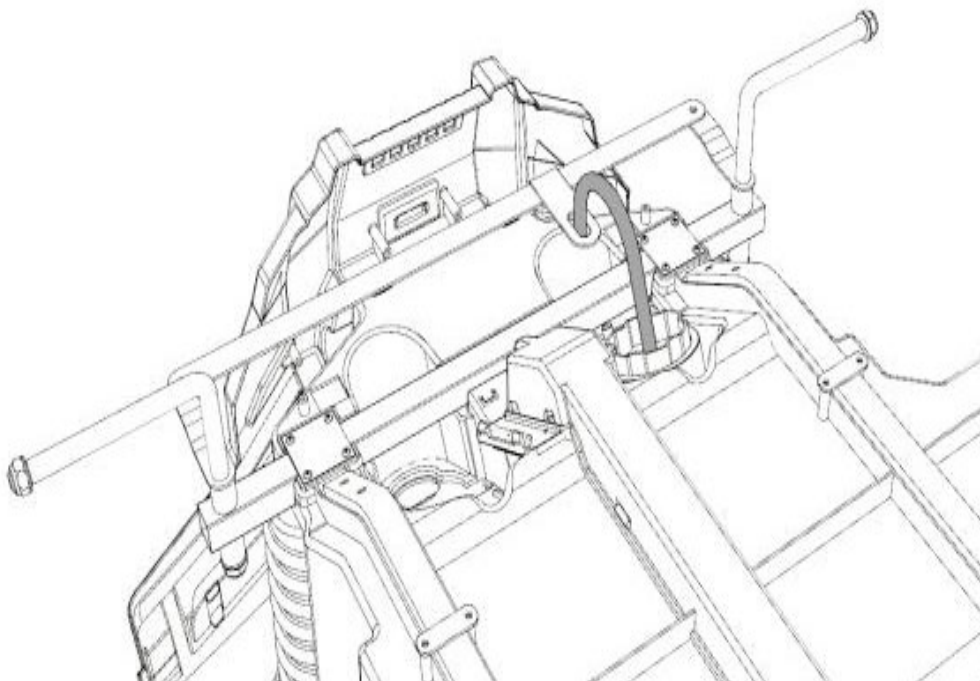

A. Turn the steer rod hook to make the hook head right to the steer rod hole of the steer structure, press it to make it through the rod hole. Then put the M10 shim on the hook head, and lock the head by the split pin.

5. Wheels and steer wheel Assembling

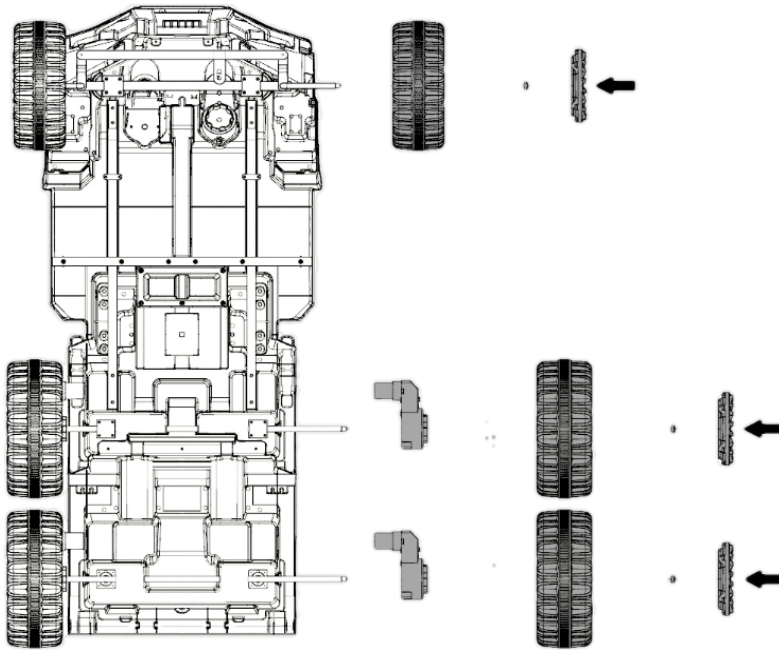

A. Put the axles through the body, and assemble the motor, wheel by shim and M10 nut, then fix the wheel cover on to right buckle position and press it to lock. (Note: motors need to be distinguished as Left & Right.)

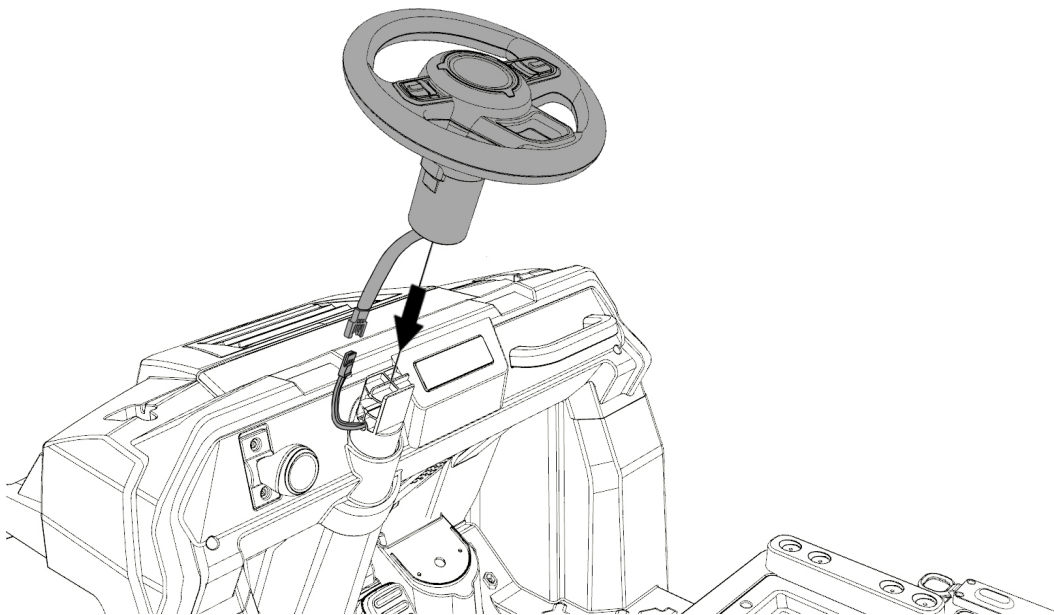

B. Connect the wire of steer wheel with the car side, make sure the wire connection is color to color, then insert the wire into the wire hole and then put the steer wheel on, fix it by buckle lock.

6. Windshield, chimney and hopper baffle assembling

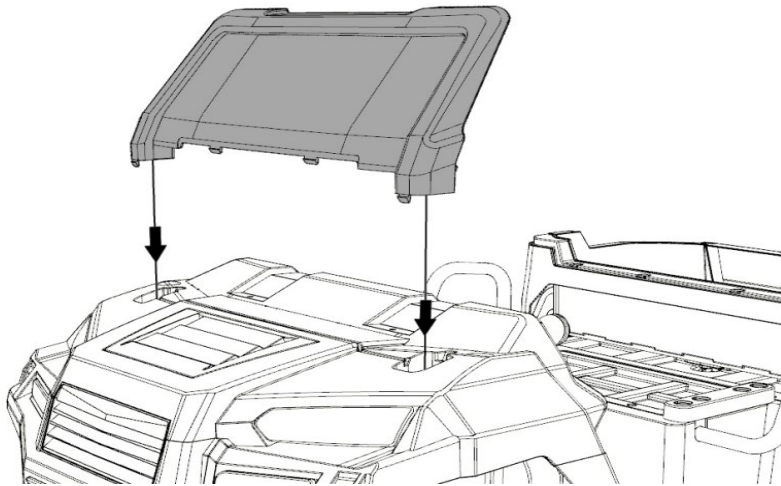

A. Stuck the windshield into the slot, and fix it by 2 pcs tapping screws.

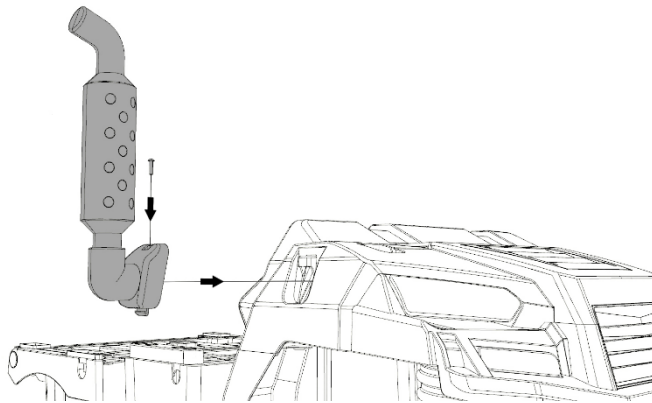

B. Stuck the chimney into the slot, and fix it by 4 pcs tapping screws.

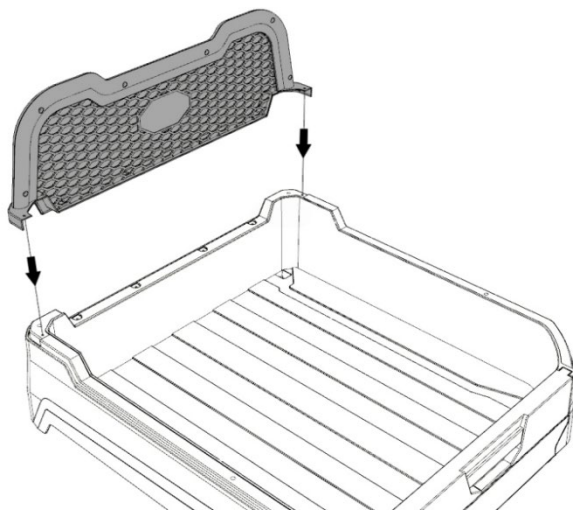

C. Put the hopper baffle onto right position and fix it by 6 tapping screws.

Assembly Steps

Install the tailgate .

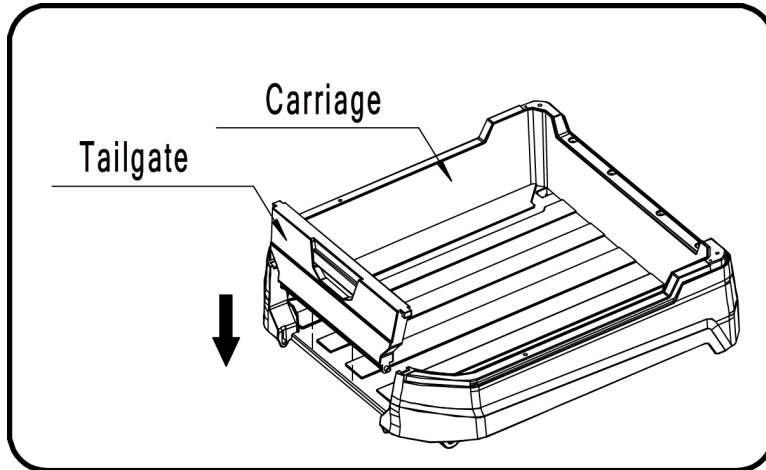

- As shown in the picture, ,install the tailgate to the corresponding place,

Install the carriage.

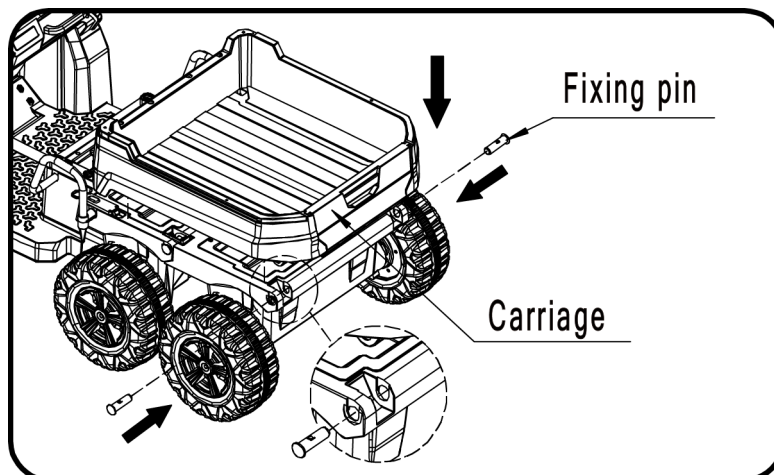

- As shown in the picture, ,install the carriage to the corresponding place,and fasten with the fixing pin.

Install the spring decoration

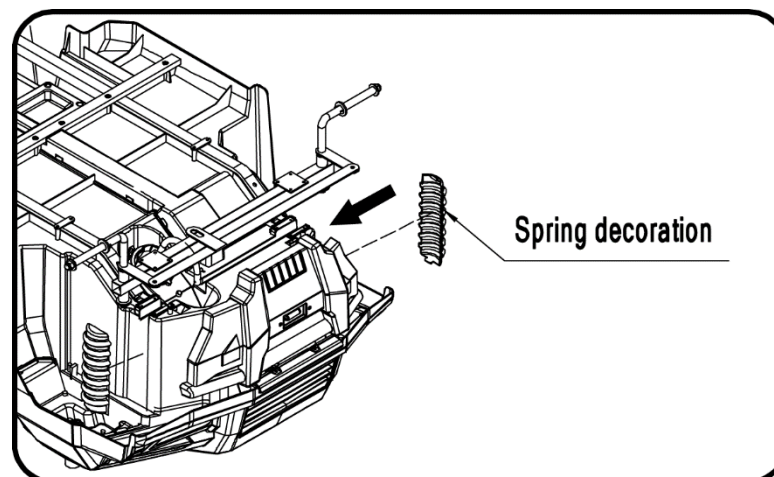

- As shown in the picture, ,install the spring decoration to the corresponding place.

7. Battery wire connection,

metal rail and seat assembling.

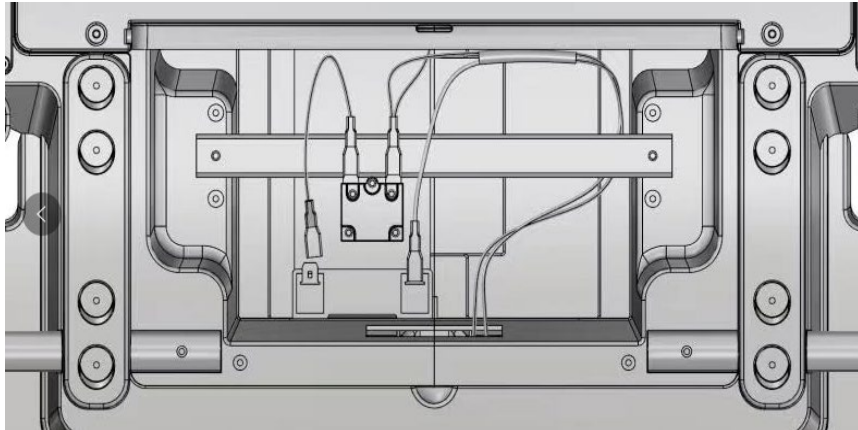

A. Connect the battery wire terminals by color to color, and then connect the motor terminals to to other 2 terminals from the controller wire terminals, no color difference;

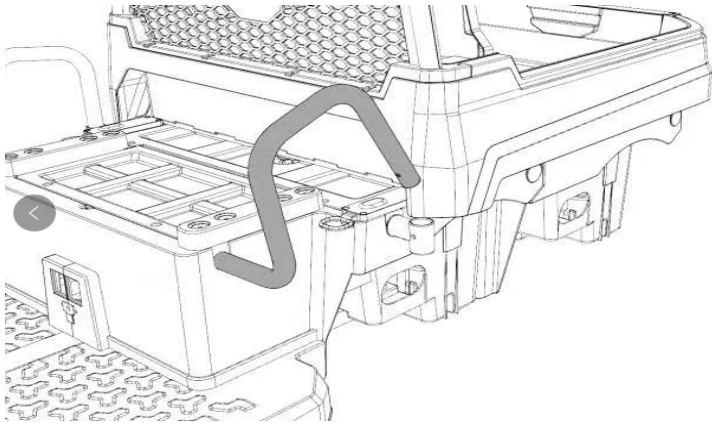

B. Check the picture, insert 2 sides of the metal rail into 2 holes, and fix it by 2 tapping screws and 1 machine screw & nut, then cover the battery compartment and fix it by tapping screws.

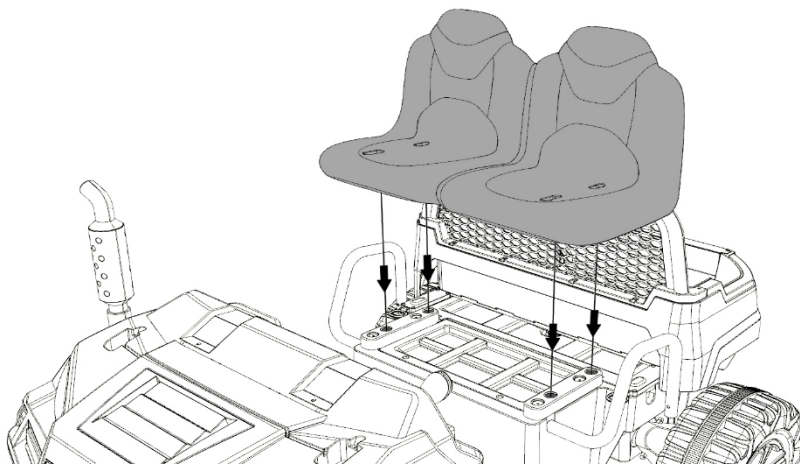

C. Put the seat onto right position and fix it by 4 tapping screws.

Be noted the seat could be adjusted by different screw holes position.

8. Functions Sketch

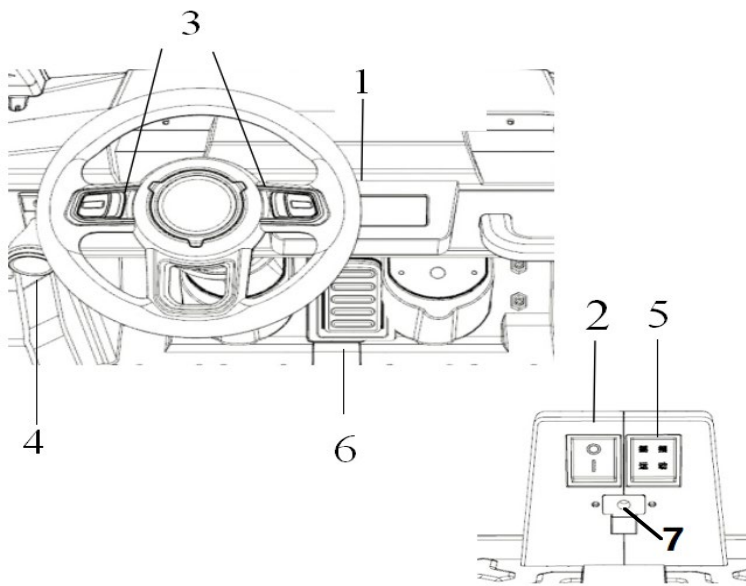

9. Functions of Remote:

Note: Use screwdriver to get screws off and open battery box, install 2 pc AAA 1.5V battery in, and fix it with screws.

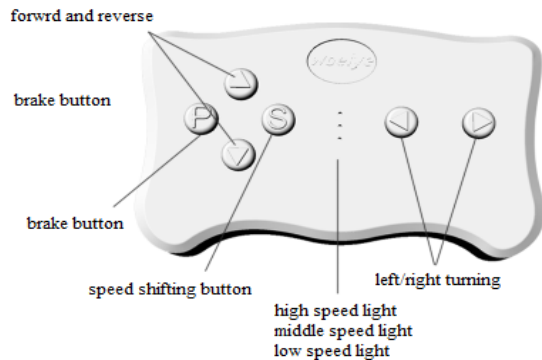

Warning !

Remote is for adult using only. Kids are prohibited to use remote.

The car is with remote priority function: while it is controlled by remote, the step switch does not work; Disconnect the remote , the step switch works then.

Remote: Open the battery holder and put in 2 pcs AAA LRO3 batteries. If the batteries are well fixed, there are frequency light and speed light will be on. Pls be noted that we supply no battery for the remote.

- 1) . Frequency connection: Press frequency button 2-4 seconds. Power on the car while low speed light flickers. It connects automatically when you see the low speed light keep on. If the light still flickers, take out the battery and restart it again as above steps.
- 2) . Braking Button: press the braking button, the car stops. Press it again, braking function is relieved.
- 3) . Speed button: Press S button to change speed. Press 1 time means speed changing 1 time. 3 lights on the remote means 3 speeds, upper light means high speed, middle light means middle, and the down button is for low speed Notes: Speed shift for forward only.
- 4) Forward/reverse button: It's to control the car to move forward and reverse. Press 1 button, the car will move as ordered, and the speed will get higher gradually to set speed to avoid sudden shock from speed-up.
- 5) Turning right/left button: It's for remote the car to turn to right or left.

Special note:

The remote has energy-saving function. 10 seconds set-aside will make it power off itself, and all lights will be off. Press any button then will make it wake up back to work.

Warning!

- Choking Hazard: Small parts, Not for kids under 3 years.
- Dispose plastic bags carefully. It's dangerous to kids.
- Adult assembly required. Use care when unpacking as components to be assembled may pose small parts/sharp edge hazard.
- Check if the charger is in good state, including the wire, socket, and all details. Stop use it if it looks broken in some way, till it's fixed.

Don't drive in below areas:

1. Glass, by the river, not flat road, and slope area;
2. Public road and other vehicles and walking people areas;
3. Where it's possible to hit or hit the other things;
4. Other not safe areas.
5. Don't drive in dark evening and night.
6. Don't drive in rain or snow. Don't drive if age or weight is not proper.



11. Special Notes before Charging:

Charging must be done by adult. Children are prohibited to touch charger and battery.

Warning!

1. Only appointed battery and charger brand are allowed to use to the car.
2. Don't use the car's battery or charger to other products.
3. Don't change the structure or cable lines.
4. Don't connect the positive pole and negative pole by tools.
5. Always keep the battery dry.
6. Keep the battery away from fire or smoking, especially while charging.
7. Charge the car in dry and well-ventilated places.
8. Don't open the battery & charger.
9. Dong put the battery upside down.
10. Don't charge if something wrong with the charger.
11. Battery heats while charging but stop and check it if its too hot.
12. Always keep the battery fastened well.
13. Keep it fully charge if not using, and 1 time per month.
14. Charger and battery are not toys. Keep them away from Children.

- Switch of the car while charging.
- Charge the car for 4-6 hours before 1st time using but no more than 10 hours
- Charge the car on time if the speed gets lower after using.
- Charge the car 8-12 hours every time after using but no more than 20 hours.

12. Warning on battery & charging!

1. Don't change the structure and electric cables. Repairing must be by professional staff.
2. Don't use it in other functions.
3. Connect the battery in right order.
4. Don't connect battery in short circuit.
5. No charging battery can't be charged.
6. Charging must be arranged by Adult, or by their guidance.
7. Don't mixed different types of battery in one car.
8. Get rid of used battery properly. It's not a toy.
9. Connect the charger to the the socket directly.
10. Put the charge plug into right socket of alternating current power.
Charging must be done by adult. Please read related notes for charging carefully.

13. Fuse Maintenance:

Inspect the charger carefully regularly to check if everything is OK.

If there is somewhere with any problem, stop using it till repaired.

Fuse: The car is with self reset fuse. When its over loaded or used improperly, the fuse will power off the car for 15-20 seconds, and then to reset it. It's installed under the seat.

To avoid related troubles from the fuse

- 1) Don't load over 60 kg
 - 2) Don't draft anything by the car.
 - 3) Don't spoil wires and electric parts with water or other liquids.
 - 4) Don't change the electric system and structure freely.
- Inspect the charger carefully regularly to check if everything is OK. If there is somewhere with any problem, stop using it till repaired.
 - Lubricate related metal parts by some lubricating oil after period using to avoid abrasion and rust.
 - The car should be placed away from fire and avoid long time strong sunshine. Don't turn upside and down and tilt. Place it indoor in wet weather or cover it with tarp.
 - The car should be kept away from hot objects such as oven or heater and etc to avoid hurting the plastic parts. Keep the car away from the easy inflammable items to avoid fire.
 - To maintain the battery, charge it every time after using; Charging must be fixed by adult; Always keep it fully charged before long time keep, and charge it 1 time a month is necessary for keeping.
 - Clean the car with dry textile. Don't use chemical liquids to clean. Don't use soap and water to clean. Don't drive the car in raining or snowing weather, which will hurt the motor, battery, and cables.
 - Power of the car if keep for long time keeping.
 - Use proper fuse accordingly to this car.
 - Don't change the cable lines and structures. Repairing must be arranged by professional staff.

14. Trouble Shooting

| Troubles | Inspections | Solutions |
|--------------------------------|--|---|
| Motor not rotating | <ol style="list-style-type: none"> 1. Check if fuse disconnected? 2. Check if pedal switch in poor contact. 3. Check if motor terminal welded. 4. Check if motor lead wires connected. 5. Connect motor & battery, check if OK. | <p>Yes, restart the car; No, check the next; No, repair the contact. Yes, check the next; No, connect it. Yes, check the next; No, connect it. Yes, check the next; No, change the motor; yes, control board broken. Contact with the shop.</p> |
| Only forward or only reverse | <ol style="list-style-type: none"> 1. check if forward/reverse switch well connected. 2. Check if all cables are well connected. | <p>No, change the switch; Yes, get to the next; No, connect them; Yes, control board broken. Contact with the seller.</p> |
| Over low speed | <ol style="list-style-type: none"> 1. check the battery voltage? 2. Check if the speed is faster if connect the motor to the battery directly? | <p>No, charging; yes, get to the next. Yes, driving control board need to be repaired. Contact with the seller.</p> |
| No feedback from car to remote | <ol style="list-style-type: none"> 1. Check if braking works. 2. Check if remote with battery. 3. Check if receiving cables well connected. | <p>Yes, press braking to relief brake; No, normal. Yes, connect it ; No, install battery. Yes, connect all cables again. No, Normal.</p> |
| Ineffective charging | <ol style="list-style-type: none"> 1. Check if battery cable connected. 2. Check if charger get heated while charging. | <p>Yes, connect them. No, get to the next. No, broken charger. Contact with the seller.</p> |
| No sound and light. | <ol style="list-style-type: none"> 1. Check if sound & light switch well connected? 2. Check if all cables well connected from the battery to other parts of the car. | <p>No, change a new switch; Yes, check the next. No, reconnect them.</p> |
| Wheels no turning | <ol style="list-style-type: none"> 1. Check if the driver is over 100 KG. 2. Check if road is not flat. 3. Check if free wheel turning OK. | <p>Yes, normal; No, get to next. Yes, normal, the car moves normal on flat road. No, get to next. No, the wheels and axles are OK.</p> |
| The car stops once a while | <ol style="list-style-type: none"> 1. check the battery voltage. 2. Check if the speed is faster if connect the motor to the battery directly? | <p>No, charging; yes, get to the next. Yes, driving control board need to be repaired. Contact with the seller.</p> |



WARNING:

**DISPOSAL OF BATTERIES: CONTAINS SEALED LEAD ACID BATTERY.
BATTERY MUST BE RECYCLED.**

Dispose old batteries at an approved battery dumping station;

Contact your local environmental protection agency office for additional information.



WARNING!

Adult assembly required.

Use care when unpacking as components to be assembled may pose small parts/sharp edge hazard.

Never leave child unattended.

To reduce the risk of injury, adult supervision is required.

The ride on is unsuitable for children under 36 months due to its maximum speed;
Maximum user weight is 60 kg.

Always sit on the seat.

Always wear shoes, and never allow more than 2 riders.

Protective equipment should be worn.

Never use in roadways, near motor vehicles, on or near steep inclines or steps, swimming pools or other bodies of water.

Direct adult supervision is required. Always keep child in vision when child in vehicles.

Execution Standard:

EN71 -1: EN71-1:2014+A1:2018 for mechanical and physical properties;

EN71-2: 2011+A1:2014 flammability test;

EN71-3:2019 on migration of certain elements;

EN62115:2005+A12:2015 on safety of electric toy Excluding clause Excluding Annex E & Annex ZC & Annex;

U.S. ASTM F963-17 For Physical And Mechanical Tests Excluding Section 4.25, 5.15, 6.5, 6.6, 7.2;

U.S. ASTM F963-17 For Flammability Test Of Materials Other Than Textile Materials;

U.S. ASTM F963-17 Section 4.3.5.2(2)(b) For Soluble Elements Content For Non-Surface Coating Materials;

U.S. ASTM F963-17 For Soluble Elements Content In Surface Coating;

U.S. ASTM F963-17 For Total Lead Content.

